



Design No. L511
BXUV.L511
Fire Resistance Ratings - ANSI/UL 263

Page Bottom

Design/System/Construction/Assembly Usage Disclaimer

- Authorities Having Jurisdiction should be consulted in all cases as to the particular requirements covering the installation and use of UL Certified products, equipment, system, devices, and materials.
 - Authorities Having Jurisdiction should be consulted before construction.
 - Fire resistance assemblies and products are developed by the design submitter and have been investigated by UL for compliance with applicable requirements. The published information cannot always address every construction nuance encountered in the field.
 - When field issues arise, it is recommended the first contact for assistance be the technical service staff provided by the product manufacturer noted for the design. Users of fire resistance assemblies are advised to consult the general Guide Information for each product category and each group of assemblies. The Guide Information includes specifics concerning alternate materials and alternate methods of construction.
 - Only products which bear UL's Mark are considered Certified.
-

BXUV - Fire Resistance Ratings - ANSI/UL 263

BXUV7 - Fire Resistance Ratings - CAN/ULC-S101 Certified for Canada

[See General Information for Fire-resistance Ratings - ANSI/UL 263](#)

[See General Information for Fire Resistance Ratings - CAN/ULC-S101 Certified for Canada](#)

Design No. L511

February 26, 2015

Unrestrained Assembly Rating — 2 Hr.

Finish Rating — 71 Min.

This design was evaluated using a load design method other than the Limit States Design Method (e.g., Working Stress Design Method). For jurisdictions employing the Limit States Design Method, such as Canada, a load restriction factor shall be used — See Guide [BXUV](#) or [BXUV7](#)

*** Indicates such products shall bear the UL or cUL Certification Mark for jurisdictions employing the UL or cUL Certification (such as Canada), respectively.**

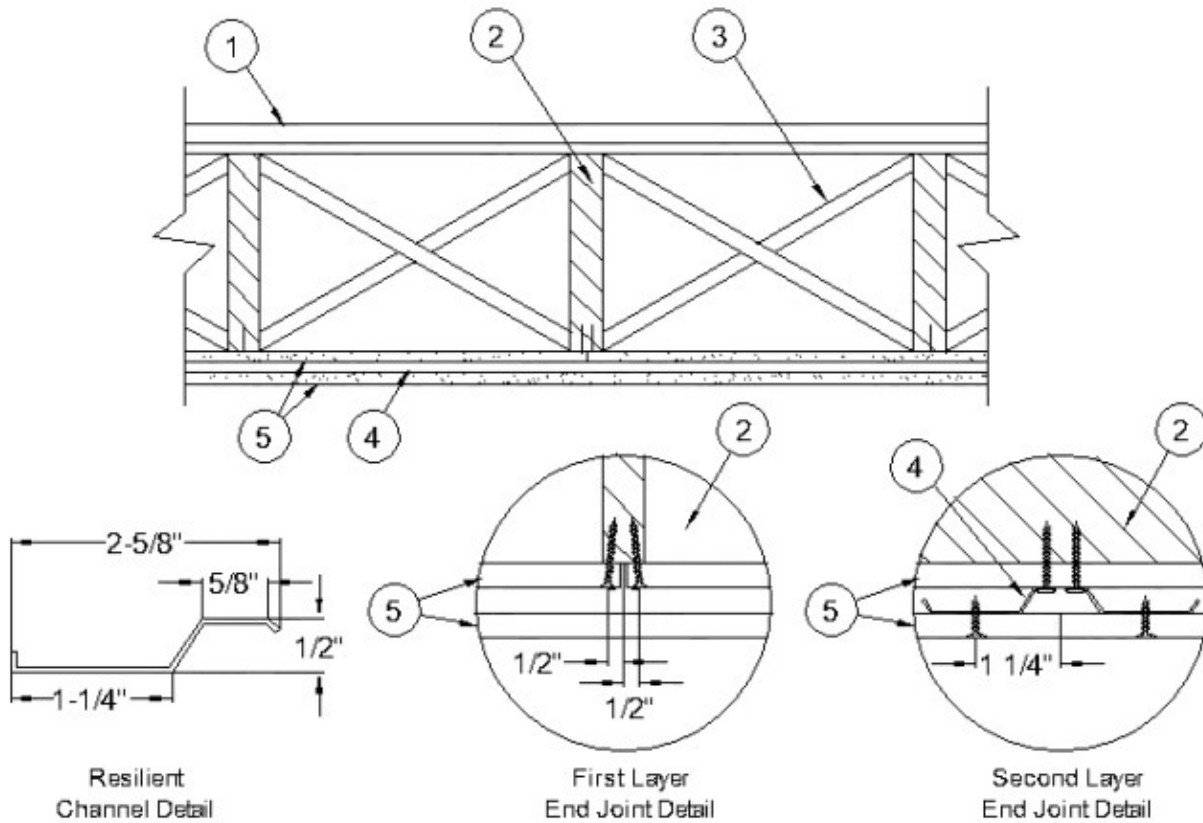

1. **Flooring Systems** — The flooring system shall consist of one of the following:

System No. 1

Subflooring — Min 1 by 6 in. T & G lumber fastened diagonally to joists.

Subflooring (Alternate) - Structural Cement-Fiber Units* — Nominal 19 mm (3/4 in.) thick tongue and groove structural cement-fiber units. Long dimension of panels to be perpendicular to joists with end joints staggered. Panels fastened to the joists with #10 self-drilling, self-tapping cement board screws 1-3/4 in. long. Screws shall be spaced 6 in. OC along the perimeter of each sheet and 12 in. OC in the field of each sheet. Screws shall be spaced 1/2 in. from end joints and 1 in. from side joints.

ECTEK INTERNATIONAL INC — Armoroc Panel

Vapor Barrier — Nom 0.010 in. thick commercial rosin-sized building paper.

Finish Flooring — Min 1 by 3 in. T & G and end matched, laid perpendicular to joists.

System No. 2

Subflooring — Min 15/32 in. thick wood structural panels, min grade "C-D" or "Sheathing". Face grain of plywood or strength axis of panels to be perpendicular to the joists with joints staggered.

Vapor Barrier - (Optional) — Nom 0.010 in. thick commercial asphalt saturated felt.

Finish Flooring - Floor Topping Mixture* — Min 3/4 in. thickness of floor topping mixture having a minimum compressive strength of 1800 psi. Refer to manufacturer's instructions accompanying the material for specific mix design.

UNITED STATES GYPSUM CO — Types LRK, HSLRK, CSD

Floor Mat Materials* — (Optional) - Floor mat material loose laid over the subfloor. Refer to manufacturer's instructions regarding the minimum thickness of floor topping over each floor mat material.

UNITED STATES GYPSUM CO — Types SAM, LEVELROCK® Brand Sound Reduction Board, LEVELROCK® Brand Floor Underlayment SRM-25

Alternate Floor Mat Materials* (Optional) — Nom 3/8 in. thick floor mat material loose laid over the subfloor. Floor topping thickness shall be as specified under **Floor Topping Mixture***.

GRASSWORX L L C — Type SC50

System No. 3

Subflooring — Min 15/32 in. thick wood structural panels, min grade "C-D" or "Sheathing". Face grain of plywood or strength axis of panels to be perpendicular to the joists with joints staggered.

Vapor Barrier - (Optional) — Nom 0.010 in. thick commercial rosin-sized building paper.

Finish Flooring — Min 19/32 in. wood structural panels, min grade "Underlayment" or "Single Floor". Face grain of plywood or strength axis of panels to be perpendicular to joists with joints staggered.

System No. 4

Subflooring — Min 15/32 in. thick wood structural panels, min grade "C-D" or "Sheathing". Face grain of plywood or strength axis of panels to be perpendicular to the joists with joints staggered.

Vapor Barrier - (Optional) — Nom 0.010 in. thick commercial rosin-sized building paper.

Finish Flooring — Floor Topping Mixture* — Min 1-1/2 in. thickness of floor topping mixture having a min compressive strength of 1000 psi and a cast density of 100 plus or minus 5 pcf. Foam concentrate mixed 40:1 by volume with water and expanded at 100 psi through nozzle. Mixture shall consist of 1.4 cu feet of preformed foam concentrate to 94 lbs Type I Portland cement, 300 lbs of sand with 5-1/2 gal of water.

ELASTIZELL CORP OF AMERICA — Type FF

System No. 5

Subflooring — Min 15/32 in. thick wood structural panels, min grade "C-D" or "Sheathing". Face grain of plywood or strength axis of panels to be perpendicular to the joists with joints staggered.

Vapor Barrier - (Optional) — Nom 0.010 in. thick commercial rosin-sized building paper.

Floor Mat Materials* - (Optional) — Floor mat material nom 5/64 in. (2mm) thick adhered to subfloor with Hacker Floor Primer. Primer to be applied to the surface of the mat prior to the placement of a min 1-1/4 in. of floor-topping mixture.

ECORE INTERNATIONAL INC — Type QTscu 4002

HACKER INDUSTRIES INC — Type Hacker Sound-Mat.

Alternate Floor Mat Materials - (Optional) — Floor mat material nom 1/4 in. (6mm) thick adhered to subfloor with Hacker Floor Primer. Primer to be applied to the surface of the mat prior to the placement of a min 1-1/4 in. (32mm) of floor-topping mixture.

ECORE INTERNATIONAL INC — Type QTrbm 3006-3

HACKER INDUSTRIES INC — Type Hacker Sound-Mat II.

Alternate Floor Mat Materials - (Optional) — Floor mat material nom 1/8 in. (3mm) thick loose laid over the subfloor. Floor topping thickness shall be a min of 1 in. (25mm)

HACKER INDUSTRIES INC — FIRM-FILL SCM 125

Alternate Floor Mat Materials - (Optional) — Floor mat material nom 1/4 in. (6mm) thick loose laid over the subfloor. Floor topping thickness shall be a min of 1 in. (25mm)

HACKER INDUSTRIES INC — Type FIRM-FILL SCM 250, Quiet Qurl 55/025

Alternate Floor Mat Materials - (Optional) — Floor mat material nom 3/8 in. (10mm) thick loose laid over the subfloor. Floor topping thickness shall be a min of 1-1/4 in. (32mm)

HACKER INDUSTRIES INC — FIRM-FILL SCM 400, Quiet Qurl 60/040

Alternate Floor Mat Materials - (Optional) — Floor mat material nom 3/4 in. (19mm) thick loose laid over the subfloor. Floor topping thickness shall be a min of 1-1/2 in. (38mm)

HACKER INDUSTRIES INC — Type FIRM-FILL SCM 750, Quiet Qurl 65/075

Metal Lath (Optional) — For use with 3/8 in. (10 mm) floor mat materials, 3/8 in. expanded steel diamond mesh, 3.4 lbs/sq yd placed over the floor mat material. Hacker Floor Primer to be applied prior to the placement of the metal lath. When metal lath is used, floor topping thickness a nom 1-1/4 in. over the floor mat.

Finish Flooring — Floor Topping Mixture* — Min 3/4 or 1 in. thickness of floor topping mixture for min 19/32 or min 15/32 in. thick wood structural panels respectively, having a min compressive strength of 1100 psi. Mixture shall consist of 6.8 gal of water to 80 lbs of floor topping mixture to 1.9 cu ft of sand.

HACKER INDUSTRIES INC — Firm-Fill Gypsum Concrete, Firm-Fill 2010, Firm-Fill 4010, Firm-Fill High Strength, Gyp-Span Radiant, Firm-Fill 3310.

System No. 6

Subflooring — Min 15/32 in. thick wood structural panels, min grade "C-D" or "Sheathing". Face grain of plywood or strength axis of panels to be perpendicular to the joists with joints staggered.

Vapor Barrier - (Optional) — Nom 0.010 in. thick commercial rosin-sized building paper.

Finish Flooring - Floor Topping Mixture* — Min 1 in. thickness of floor topping mixture having a min compressive strength of 1000 psi and a cast density of 100 plus or minus 5 pcf. Foam concentrate mixed 40:1 by volume with water and expanded at 100 psi through nozzle. Mixture shall consist of 1.4 cu feet of preformed foam concentrate to 94 lbs Type I Portland cement, 62.5 lb of pea gravel, 312.5 lbs of sand with 5-1/2 gal of water.

LITE-CRETE INC — Type I

System No. 7

Subflooring — Min 15/32 in. thick wood structural panels, min grade "C-D" or "Sheathing". Face grain of plywood or strength axis of panels to be perpendicular to the joists with joints staggered.

Vapor Retarder — (Optional) — Nom 0.030 in. thick commercial asphalt saturated felt.

Finish Flooring — Floor Topping Mixture* — Min 3/4 or 1 in. thickness of floor topping mixture for min 19/32 or min 15/32 in. thick wood structural panels respectively, having a min compressive strength of 1000 psi. Mixture shall consist of 5 to 8 gal of water to 80 lbs of floor topping mixture to 2.1 cu ft of sand.

ULTRA QUIET FLOORS — Types UQF-A, UQF-Super Blend, UQF-Plus 200

System No. 8

Subflooring — Min 15/32 in. thick wood structural panels, min grade "C-D" or "Sheathing". Face grain of plywood or strength axis of panels to be perpendicular to the joists with joints staggered.

Vapor Barrier — (Optional) — Nom 0.030 in. thick commercial asphalt saturated felt.

Floor Mat Materials* - (Optional) — Nom 1/4 in. thick floor mat material loose laid over the subfloor. Maxxon Floor Primer to be applied to the surface of the mat prior to the floor topping placement. When floor mat material is used, min thickness of floor topping mixture is 1 in. Floor topping thickness a min 3/4 in. over Acousti-Mat I floor mat.

MAXXON CORP — Type Acousti-Mat I, Acousti-Mat II, Acousti-Mat II HP.

Alternate Floor Mat Materials* — (Optional) — Nom 0.8 in. thick floor mat material loose laid over the subfloor with Crack Suppression Mat (CSM) loose laid over the floor mat material. Floor topping thickness shall be min 1-1/2 in.

MAXXON CORP — Type Acousti-Mat 3, Acousti-Mat 3 HP, Crack Suppression Mat (CSM)

Metal Lath — (Alternate to Crack Suppression Mat (CSM)) — 3/8 in. expanded galvanized steel diamond mesh, 3.4 lbs/sq yd loose laid over the floor mat material. Floor topping thickness shall be min 1-1/2 in.

Fiber Glass Mesh Reinforcement — (Optional) — Maxxon Corp's "Maxxon Reinforcement (MR)" for use with or as an alternate to CSM or metal lath reinforcement, the materials consists of a plastic coated non-woven fiber glass mesh grid intended to suppress cracks in the Floor Topping Mixture.

Alternate Floor Mat Materials* — (Optional) — Nom 0.4 in. thick floor mat material loose laid over the subfloor. Maxxon Floor Primer to be applied to the surface of the mat prior to the floor topping placement. Floor topping thickness shall be min 1 in. Floor topping thickness shall be min 3/4 in. when used with Crack Suppression Mat (CSM), Metal Lath, or Maxxon Reinforcement (MR).

MAXXON CORP — Type Enkasonic 9110, Enkasonic 9110 HP.

Alternate Floor Mat Materials* — (Optional) — Nom 0.2 in. thick floor mat material loose laid over the subfloor. Maxxon Floor Primer may be applied to the surface of the mat prior to the floor topping placement. Floor topping thickness shall be as specified under **Floor Topping Mixture**.

MAXXON CORP — Type Acousti-Mat LP-R

Metal Lath — (Optional) — For use with floor mat materials, 3/8 in. expanded galvanized steel diamond mesh, 3.4 lbs/sq

yd or Maxxon Corp. UL Classified Crack Suppression Mat (CSM) loose laid over the floor mat material. Floor topping thickness shall be min 1 in.

MAXXON CORP — Type Crack Suppression Mat (CSM)

Fiber Glass Mesh Reinforcement — (Optional) — Maxxon Corp's "Maxxon Reinforcement (MR)" for use with or as an alternate to CSM or metal lath reinforcement, the materials consists of a plastic coated non-woven fiber glass mesh grid intended to suppress cracks in the Floor Topping Mixture.

Finish Flooring — Floor Topping Mixture* — Min 3/4 or 1 in. thickness of floor topping mixture for min 19/32 or min 15/32 in. thick wood structural panels respectively, having a min compressive strength of 1000 psi. Mixture shall consist of 3 to 7 gal of water mixed with 80 lbs of floor topping mixture and 1.0 to 2.1 cu ft of sand.

MAXXON CORP — Type D-C, GC, GC2000, L-R, T-F, CT

System No. 9

Subflooring — Min 15/32 in. thick wood structural panels, min grade "C-D" or "Sheathing". Face grain of plywood or strength axis of panels to be perpendicular to the joists with joints staggered.

Vapor Barrier - (Optional) — Nom 0.030 in. thick commercial asphalt saturated felt.

Floor Mat Materials* - (Optional) — Nom 1/4 in. thick floor mat material loose laid over the subfloor. Maxxon Floor Primer to be applied to the surface of the mat prior to the floor topping placement. When floor mat material is used, min thickness of floor topping mixture is 1 in. Floor topping thickness a min 3/4 in. over Acousti-Mat I floor mat.

MAXXON CORP — Type Acousti-Mat I, Acousti-Mat II, Acousti-Mat II HP.

Alternate Floor Mat Materials* - (Optional) — Nom 0.8 in. thick floor mat material loose laid over the subfloor with Crack Suppression Mat (CSM) loose laid over the floor mat material. Floor topping thickness shall be min 1-1/2 in.

MAXXON CORP — Type Acousti-Mat 3, Acousti-Mat 3 HP, Crack Suppression Mat (CSM)

Metal Lath — (Alternate to Crack Suppression Mat (CSM)) — 3/8 in. expanded galvanized steel diamond mesh, 3.4 lbs/sq yd loose laid over the floor mat material. Floor topping thickness shall be min 1-1/2 in.

Fiber Glass Mesh Reinforcement — (Optional) — Maxxon Corp's "Maxxon Reinforcement (MR)" for use with or as an alternate to CSM or metal lath reinforcement, the materials consists of a plastic coated non-woven fiber glass mesh grid intended to suppress cracks in the Floor Topping Mixture.

Alternate Floor Mat Materials* - (Optional) — Nom 0.4 in. thick floor mat material loose laid over the subfloor. Maxxon Floor Primer to be applied to the surface of the mat prior to the floor topping placement. Floor topping thickness shall be min 1 in. Floor topping thickness shall be min 3/4 in. when used with Crack Suppression Mat (CSM), Metal Lath, or Maxxon Reinforcement (MR).

MAXXON CORP — Type Enkasonic 9110, Enkasonic 9110 HP.

Alternate Floor Mat Materials* - (Optional) — Nom 0.2 in. thick floor mat material loose laid over the subfloor. Maxxon Floor Primer may be applied to the surface of the mat prior to the floor topping placement. Floor topping thickness shall be as specified under **Floor Topping Mixture**.

MAXXON CORP — Type Acousti-Mat LP-R

Metal Lath (Optional) — For use with floor mat materials, 3/8 in. expanded galvanized steel diamond mesh, 3.4 lbs/sq yd or Maxxon Corp. UL Classified Crack Suppression Mat (CSM) loose laid over the floor mat material. Floor topping thickness shall be min 1 in.

MAXXON CORP — Type Crack Suppression Mat (CSM)

Fiber Glass Mesh Reinforcement — (Optional) — Maxxon Corp's "Maxxon Reinforcement (MR)" for use with or as an alternate to CSM or metal lath reinforcement, the materials consists of a plastic coated non-woven fiber glass mesh grid intended to suppress cracks in the Floor Topping Mixture.

Finish Flooring - Floor Topping Mixture* — Min 3/4 or 1 in. thickness of floor topping mixture for min 19/32 or min 15/32 in. thick wood structural panels respectively, having a min compressive strength of 1200 psi. Mixture shall consist of 4 to 7 gal of water mixed with 80 lbs of floor topping mixture and 1.4 to 1.9 cu ft of sand.

RAPID FLOOR SYSTEMS — Type RF, RFP, RFU, RFR, Orcrete

System No. 10

Subflooring — Min 15/32 in. thick wood structural panels, min grade "C-D" or "Sheathing". Face grain of plywood or strength axis of panels to be perpendicular to the joists with joints staggered.

Finish Floor - Mineral and Fiber Board* — Min 1/2 in. thick, supplied in sizes ranging from 3 ft by 4 ft to 8 ft by 12 ft. All joints to be staggered a min of 12 in. with adjacent sub-floor joints.

HOMASOTE CO — Type 440-32 Mineral and Fiber Board

System No. 11

Subflooring — Min 15/32 in. thick wood structural panels, min grade "C-D" or "Sheathing". Face grain of plywood or strength axis of panels to be perpendicular to the joists with joints staggered.

Vapor Barrier - (Optional) — Nom 0.030 in. thick commercial asphalt saturated felt.

Finish Flooring - Floor Topping Mixture* — Min 1-1/2 in. thickness of floor topping mixture having a min compressive strength of 1000 psi and a cast density of 105 plus or minus 5 pcf. Foam concentrate mixed 40:1 by volume with water and expanded at 100 psi through nozzle. Mixture shall consist of 1.2 cu feet of preformed foam concentrate to 94 lbs Type I Portland cement, and 300 lbs of sand with 5.5 gal of water.

AERIX INDUSTRIES — Floor Topping Mixture

System No. 12

Subflooring — Min 15/32 in. thick wood structural panels, min grade "C-D" or "Sheathing". Face grain of plywood or strength axis of panels to be perpendicular to the joists with joints staggered.

Vapor Barrier - (Optional) — Nom 0.010 in. thick commercial rosin-sized building paper.

Finish Flooring - Floor Topping Mixture* — Min 3/4 floor topping mixture, having a min compressive strength of 1000 psi. Refer to manufacturer's instructions accompanying the material for specific mix design.

ALLIED CUSTOM GYPSUM — Accu-Crete, AccuRadiant, AccuLevel G40 and AccuLevel SD30.

Alternate Floor Mat Material* - (Optional) - Floor mat material nominal 2 - 9.5 mm thick loose laid over the subfloor. Floor topping shall be a min of 3/4 in. or 1 in. thickness of floor topping mixture for 19/32 or 15/32 in. thick wood structural panels respectively.

ALLIED CUSTOM GYPSUM — Type AccuQuiet P80, Type AccuQuiet C40, AccuQuiet D13, and Type AccuQuiet D-18.

System No. 13

Subflooring — 15/32 or 19/32 in. thick wood structural panels, min. grade "C-D" or "Sheathing". Face grain of plywood or strength axis of panels to be perpendicular to joists with joints staggered.

Vapor Barrier — (Optional) — Nom 0.030 in. thick commercial asphalt saturated felt.

Finish Flooring — Floor Topping Mixture* — Min 3/4 or 1 in. thickness of floor topping mixture for 19/32 or 15/32 in. thick wood structural panels respectively, having a min compressive strength of 2100 psi. Refer to manufacturer's instructions accompanying the material for specific mix design.

BMI PRODUCTS OF NORTHERN ILLINOIS INC — Maxit 493

System No. 14

Subflooring — Min 15/32 in. thick wood structural panels, min grade "C-D" or "Sheathing". Face grain of plywood or strength axis of panels to be perpendicular to the joists with joints staggered.

Vapor Barrier — (Optional) - Commercial asphalt saturated felt, 0.030 in. thick.

Vapor Barrier — (Optional) - Nom 0.010 in. thick commercial rosin-sized building paper.

Finish Flooring* — Min 3/4 in. thickness of any Floor Topping Mixture bearing the UL Classification Marking as to Fire Resistance. See Floor- and Roof-Topping Mixtures (CCOX) category for names of Classified Companies.

Floor Mat Materials* — (Optional) - Nom. 1/4 in. thick loose laid over the subfloor. Floor topping thickness shall be a minimum of 3/4 in.

KEENE BUILDING PRODUCTS CO INC — Type Quiet Qurl 55/025 and Quiet Qurl 55/025 N

Alternate Floor Mat Materials* — (Optional) - Floor mat material Nom. 3/8 in. thick loose laid over the subfloor. Floor topping thickness shall be a minimum of 1 in.

KEENE BUILDING PRODUCTS CO INC — Type Quiet Qurl 60/040 and Quiet Qurl 60/040 N

Alternate Floor Mat Materials* — (Optional) - Floor mat material Nom. 3/4 in. thick loose laid over the subfloor. Floor

topping thickness shall be a minimum of 1-1/2 in.

KEENE BUILDING PRODUCTS CO INC — Type Quiet Qurl 65/075, Quiet Qurl 65/075 N

Alternate Floor Mat Materials* — (Optional) - Floor mat material Nom. 1/8 in. thick loose laid over the subfloor. Floor topping thickness shall be a minimum of 3/4 in.

KEENE BUILDING PRODUCTS CO INC — Type Quiet Qurl 52/013 and Quiet Qurl 52/013 N

Alternate Floor Mat Materials* — (Optional) - Floor mat material Nom. 1/4 in. entangled net core with a compressible fabric attached to the bottom loose laid over the subfloor. Floor topping thickness shall be a minimum of 1 in.

KEENE BUILDING PRODUCTS CO INC — Quiet Qurl 55/025 MT and Quiet Qurl 55/025 N MT

System No. 15

Subflooring — Min 1 by 6 in. T & G lumber fastened diagonally to joists.

Vapor Barrier — Nom 0.010 in. thick commercial rosin-sized building paper.

Finish Flooring - Floor Topping Mixture* — Min 1 in. thickness of floor topping mixture having a min compressive strength of 1000 psi. Refer to manufacturer's instructions accompanying the material for specific mix design.

ALLIED CUSTOM GYPSUM — Accu-Crete, AccuRadiant

Floor Mat Material* — (Optional) - Floor mat material nominal 2 - 9.5 mm thick loose laid over the subfloor. Floor topping shall be a min of 3/4 in.

ALLIED CUSTOM GYPSUM — Type AccuQuiet P80, Type AccuQuiet C40, Type AccuQuiet RSM 20, Type AccuQuiet RSM 32, Type AccuQuiet RSM 48, Type AccuQuiet RSM 64, and Type AccuQuiet RSM 120

System No. 16

Subflooring — Min 15/32 in. thick wood structural panels, min grade "C-D" or "Sheathing". Face grain of plywood or strength axis of panels to be perpendicular to the joists with joints staggered.

Vapor Barrier - (Optional) — Nom 0.010 in. thick commercial rosin-sized building paper.

Finish Flooring - Floor Topping Mixture* — Min 3/4 floor topping mixture, having a min compressive strength of 1000 psi. Refer to manufacturer's instructions accompanying the material for specific mix design.

DEPENDABLE LLC — GSL M3.4, GSL K2.6 and GSL RH.

Floor Mat Materials* — (Optional) - Nom. 1/4 in. thick loose laid over the subfloor. Floor topping thickness shall be a minimum of 3/4 in.

KEENE BUILDING PRODUCTS CO INC — Type Quiet Qurl 55/025 and Quiet Qurl 55/025 N

Alternate Floor Mat Materials* — (Optional) - Floor mat material Nom. 3/8 in. thick loose laid over the subfloor. Floor topping thickness shall be a minimum of 1 in.

KEENE BUILDING PRODUCTS CO INC — Type Quiet Qurl 60/040 and Quiet Qurl 60/040 N

Alternate Floor Mat Materials* — (Optional) - Floor mat material Nom. 3/4 in. thick loose laid over the subfloor. Floor topping thickness shall be a minimum of 1-1/2 in.

KEENE BUILDING PRODUCTS CO INC — Type Quiet Qurl 65/075, Quiet Qurl 65/075 N

Alternate Floor Mat Materials* — (Optional) - Floor mat material Nom. 1/8 in. thick loose laid over the subfloor. Floor topping thickness shall be a minimum of 3/4 in.

KEENE BUILDING PRODUCTS CO INC — Type Quiet Qurl 52/013 and Quiet Qurl 52/013 N

Alternate Floor Mat Materials* — (Optional) - Floor mat material Nom. 1/4 in. entangled net core with a compressible fabric attached to the bottom loose laid over the subfloor. Floor topping thickness shall be a minimum of 1 in.

KEENE BUILDING PRODUCTS CO INC — Quiet Qurl 55/025 MT and Quiet Qurl 55/025 N MT

System No. 17

Subflooring — Min 15/32 in. thick wood structural panels, min grade "C-D" or "Sheathing". Face grain of plywood or strength axis of panels to be perpendicular to the joists with joints staggered.

Vapor Barrier — (Optional) - Commercial asphalt saturated felt, 0.030 in. thick.

Vapor Barrier — (Optional) - Nom 0.010 in. thick commercial rosin-sized building paper.

Finish Flooring* — Min 3/4 in. thickness of any Floor Topping Mixture bearing the UL Classification Marking as to Fire Resistance. See Floor- and Roof-Topping Mixtures (CCOX) category for names of Classified Companies.

Floor Mat Materials* — (Optional) - Nom 3/32 in. thick loose laid over the subfloor. Floor topping thickness shall be a minimum of 3/4 in.

PLITEQ INC — Type GenieMat RST02

Floor Mat Materials* — (Optional) - Nom 3/16 in. thick loose laid over the subfloor. Floor topping thickness shall be a minimum of 3/4 in.

PLITEQ INC — Type GenieMat FF04

Floor Mat Materials* — (Optional) - Nom 1/4 in. thick loose laid over the subfloor. Floor topping thickness shall be a minimum of 3/4 in.

PLITEQ INC — Type GenieMat FF06

Floor Mat Materials* — (Optional) - Nom 3/8 in. thick loose laid over the subfloor. Floor topping thickness shall be a minimum of 1 in.

PLITEQ INC — Type GenieMat FF10

Floor Mat Materials* — (Optional) - Nom 3/4 in. thick loose laid over the subfloor. Floor topping thickness shall be a minimum of 1-1/2 in.

PLITEQ INC — Type GenieMat FF17

Floor Mat Materials* — (Optional) - Nom 1 in. thick loose laid over the subfloor. Floor topping thickness shall be a minimum of 1-1/2 in.

PLITEQ INC — Type GenieMat FF25

2. **Wood Joists** — Min 2 by 10, spaced 16 in. OC and effectively fireblocked in accordance with local codes.

3. **Cross Bridging** — Min 1 by 3 in. or min 2 by 10 solid blocking.

4. **Resilient Channels** — Formed of 25 MSG galv steel, spaced 24 in. OC perpendicular to joists and located 12 in. from each side edge of base layer gypsum board. Channels placed with 1/4 in. clearance at the ends and fastened to each joist with 1-7/8 in. long Type S bugle head screws. Min end clearance of channels to walls: 3/8 in. Additional channels 60 in. long, placed adjacent to continuous channels at end joints of second layers of gypsum board (Item 5) and similarly secured. Channel ends to extend 6 in. beyond each side of joint.

4A. **Steel Framing Members (Not Shown)*** — As an alternate to Item 4, furring channels and Steel Framing Members as described below:

a. **Furring Channels** — Formed of No. 25 MSG galv steel. 2-9/16 in. or 2-23/32 in. wide by 7/8 in. deep, spaced 24 in. OC perpendicular to joists. Channels secured to joists as described in Item b. Ends of adjoining channels overlapped 6 in. and tied together with double strand of No. 18 SWG galv steel wire near each end of overlap.

b. **Steel Framing Members*** — Used to attach furring channels (Item a) to joists. Clips spaced 48 in. OC., and secured to alternating joists with No. 8 x 2-1/2 in. coarse drywall screw through the center grommet. Furring channels are friction fitted into clips. RSIC-1 clip for use with 2-9/16 in. wide furring channels. RSIC-1 (2.75) clip for use with 2-23/32 in. wide furring channels. Adjoining channels are overlapped as described in Item a. As an alternate, ends of adjoining channels may be overlapped 6 in. and secured together with two self-tapping No. 6 framing screws, min 7/16 in. long at the midpoint of the overlap, with one screw on each flange of the channel. Additional clips required to hold furring channel that supports the gypsum board butt joints, as described in Item 5.

PAC INTERNATIONAL INC — Types RSIC-1, RSIC-1 (2.75).

4B. **Alternate Steel Framing Members** — (Not Shown)* — As an alternate to items 4, furring channels and Steel Framing

Members as described below.

a. **Furring Channels** — Formed of No. 25 MSG galv steel, 2-3/8 in. wide by 7/8 in deep, spaced 24 in OC, perpendicular to joists. Channels secured to joists as described in Item b. Ends of adjoining channels overlapped 6 in. and tied together with double strand of No. 18 SWG galv steel wire near each end of overlap.

b. **Steel Framing Members*** — Used to attach furring channels (Item a) to the wood joists (Item 2). Clips spaced 48 in. OC., and secured to alternating joists with No. 8 x 2-1/2 in. coarse drywall screw through the center grommet. Furring channels are friction fitted into clips. Adjoining channels are overlapped as described in Item a. As an alternate, ends of adjoining channels may be overlapped 6 in. and secured together with two self-tapping No. 6 framing screws, min 7/16 in. long at the midpoint of the overlap, with one screw on each flange of the channel. Additional clips required to hold furring channel that supports the gypsum board butt joints, as described in Item 5.

PLITEQ INC — Type Genie Clip

4C. **Alternate Steel Framing Members** — (Not Shown)* - As an alternate to Item 4, furring channels and Steel Framing Members as described below.

a. **Furring Channels** — Formed of No. 25 MSG galv steel, 2-5/8 in. wide by 7/8 in deep, spaced 24 in OC, perpendicular to joists. Channels secured to joists as described in Item b.

b. **Steel Framing Members*** — Used to attach furring channels (Item a) to the wood joists (Item 2). Clips spaced at 24" OC and secured to the bottom of the joists with one No. 10 x 2-1/2 Coarse Drywall Screw through the center hole. Furring channels are then friction fitted into clips. Ends of channels are overlapped 6" and screwed with four No. 8 x 1/2 Self Drilling screws (2 per side 1 in. and 4 in. from overlap edge). Additional clips are required to hold the Gypsum Butt joints and side joints as described in Item 5.

STUDCO BUILDING SYSTEMS — RESILMOUNT Sound Isolation Clips - Type A237R

5. **Gypsum Board*** — Two layers of nom 5/8 in. thick, 4 ft wide gypsum board. When resilient channels (Item 4) are used, first layer installed perpendicular to joists with end joints located over bottom of joists. Gypsum board attached to joists with 6d cement coated cooler nails spaced 1 in., 6 in. and 21 in. from each side edge in the field of the board. Butt edges shall occur under joists, fastened with nails spaced 1 in., 6 in., 15 in. and 21 in. from side edges of board, and 1/2 in. back from butt edge. Second layer of gypsum board secured to resilient channels with 1 in. long Type S bugle head screws spaced 12 in. OC with additional screws placed 3 in. from each side edge. End joints of second layer offset from end joints in first layer, and secured to both resilient channels as shown in end joint detail. Screws located 3/4 in. and 1-1/4 in. from side and end joints of boards. When **Steel Framing Members** (Item 4A or 4B) are used, sheets installed with long dimensions parallel with joists. Base layer attached to the furring channels using 1 in. long Type S bugle head steel screws spaced 8 in. OC along butted end joints and 12 in. OC in the field of the board. Butted end joints shall be staggered min 2 ft. within the assembly, and occur midway between the continuous furring channels. Each end of each gypsum board shall be supported by a single length of furring channel equal to the width of the gypsum board plus 6 in. on each end. The two furring channels shall be spaced approximately 3-1/2 in. OC, and be attached to underside of the joist with one RSIC-1 or Genie clip at each end of the channel. Butted base layer end joints to be offset a min of 24 in. in adjacent courses. Outer layer attached to the furring channels using 1-5/8 in. long Type S bugle head steel screws spaced 8 in. OC at butted joints and 12 in. OC in the field. Butted end joints to be offset a min of 8 in. from base layer end joints. Butted side joints of outer layer to be offset min 18 in. from butted side joints of base layer. When **Steel Framing Members** (Item 4C) are used, base layer of gypsum board is installed with long dimensions perpendicular to furring channels. Gypsum board secured to furring channels with nom 1 in. long Type S bugle-head steel screws spaced 8 in. OC in the field of the board. Gypsum board butted end joints shall be staggered minimum 72 in. At the gypsum board butt joints, each end of each gypsum board shall be supported by a single length of furring channel equal to the width of the gypsum board plus 3 in. on each end, spaced approximately 2 in. in from joint. Screw spacing along the gypsum board butt joint shall be 8 in. OC. Butt joint furring channels shall be attached with a RESILMOUNT Sound Isolation Clip secured to underside of every joist that is located over the butt joint. Over all Gypsum Board side joints, approximately 20 in. lengths of furring channel shall be installed parallel to joists (Item 2) between main furring channels. Side joint furring channels shall be attached to underside of the joist with RESILMOUNT Sound Isolation Clips - Type A237R located approximately 2 in. from each end of the approximate 20 in. length of channel. Both Gypsum Boards at side joints fastened into channel with screws spaced 8 in. OC, approximately 1/2 in. from joint edge. Face layer installed per Item 5.

AMERICAN GYPSUM CO — Type AG-C

CERTAINTED GYPSUM INC — Type FRPC, Type C

CGC INC — Types C, IP-X2, IPC-AR

CONTINENTAL BUILDING PRODUCTS OPERATING CO, L L C — Type LGFC-C/A

GEORGIA-PACIFIC GYPSUM L L C — Types 5, DAPC, TG-C

NATIONAL GYPSUM CO — Types FSK-C, FSW-C, FSW-G

PABCO BUILDING PRODUCTS L L C, DBA PABCO GYPSUM — Type C

PANEL REY S A — Type PRC

THAI GYPSUM PRODUCTS PCL — Type C

UNITED STATES GYPSUM CO — Types C, IP-X2, IPC-AR

USG MEXICO S A DE C V — Types C, IP-X2, IPC-AR

6. **Finishing System - (Not Shown)** — Vinyl, dry or premixed joint compound, applied in two coats to joints and screw-heads. Nom 2 in. wide paper tape embedded in first layer of compound over all joints. As an alternate, nom. 3/32 in. thick veneer plaster may be applied to the entire surface of the gypsum board.

*** Indicates such products shall bear the UL or cUL Certification Mark for jurisdictions employing the UL or cUL Certification (such as Canada), respectively.**

Last Updated on 2015-02-26

[Questions?](#)

[Print this page](#)

[Terms of Use](#)

[Page Top](#)

© 2015 UL LLC

When the UL Leaf Mark is on the product, or when the word "Environment" is included in the UL Mark, please search the [UL Environment database](#) for additional information regarding this product's certification.

The appearance of a company's name or product in this database does not in itself assure that products so identified have been manufactured under UL's Follow-Up Service. Only those products bearing the UL Mark should be considered to be Certified and covered under UL's Follow-Up Service. Always look for the Mark on the product.

UL permits the reproduction of the material contained in the Online Certification Directory subject to the following conditions: 1. The Guide Information, Assemblies, Constructions, Designs, Systems, and/or Certifications (files) must be presented in their entirety and in a non-misleading manner, without any manipulation of the data (or drawings). 2. The statement "Reprinted from the Online Certifications Directory with permission from UL" must appear adjacent to the extracted material. In addition, the reprinted material must include a copyright notice in the following format: "© 2015 UL LLC".