



Design No. M501
BXUV.M501
Fire Resistance Ratings - ANSI/UL 263

Page Bottom

Design/System/Construction/Assembly Usage Disclaimer

- Authorities Having Jurisdiction should be consulted in all cases as to the particular requirements covering the installation and use of UL Certified products, equipment, system, devices, and materials.
 - Authorities Having Jurisdiction should be consulted before construction.
 - Fire resistance assemblies and products are developed by the design submitter and have been investigated by UL for compliance with applicable requirements. The published information cannot always address every construction nuance encountered in the field.
 - When field issues arise, it is recommended the first contact for assistance be the technical service staff provided by the product manufacturer noted for the design. Users of fire resistance assemblies are advised to consult the general Guide Information for each product category and each group of assemblies. The Guide Information includes specifics concerning alternate materials and alternate methods of construction.
 - Only products which bear UL's Mark are considered Certified.
-

BXUV - Fire Resistance Ratings - ANSI/UL 263

BXUV7 - Fire Resistance Ratings - CAN/ULC-S101 Certified for Canada

[See General Information for Fire-resistance Ratings - ANSI/UL 263](#)

[See General Information for Fire Resistance Ratings - CAN/ULC-S101 Certified for Canada](#)

Design No. M501

February 26, 2015

Unrestrained Assembly Rating — 1 Hr.

Finish Rating — 23 Min (See Items 5 or 5A)

This design was evaluated using a load design method other than the Limit States Design Method (e.g., Working Stress Design Method). For jurisdictions employing the Limit States Design Method, such as Canada, a load restriction factor shall be used — See Guide [BXUV](#) or [BXUV7](#)

*** Indicates such products shall bear the UL or cUL Certification Mark for jurisdictions employing the UL or cUL Certification (such as Canada), respectively.**

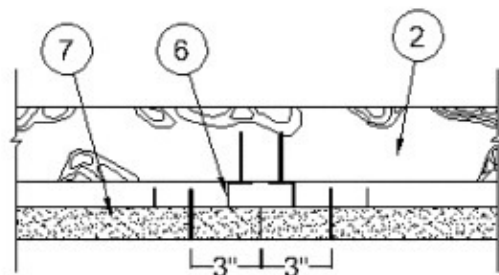
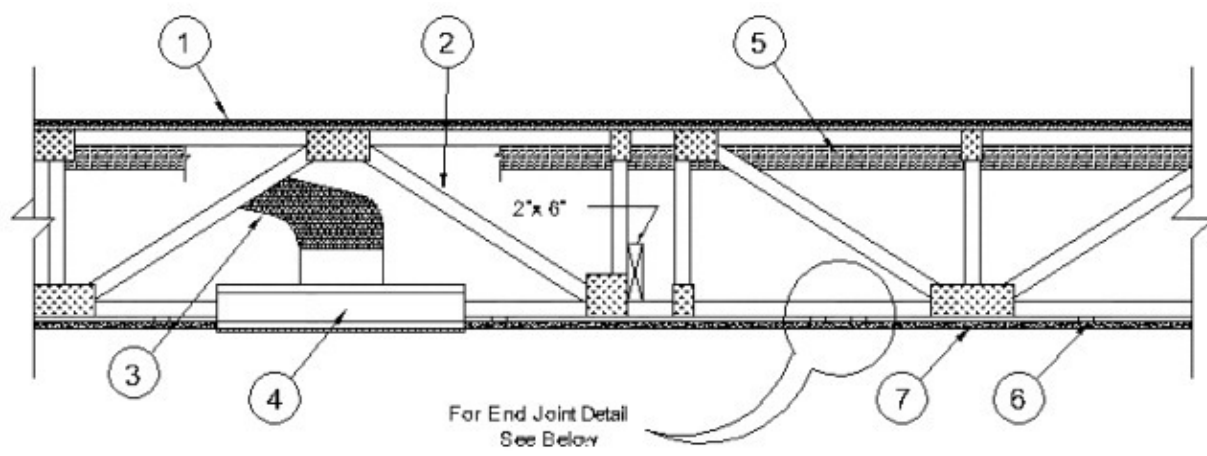

End Joint Detail

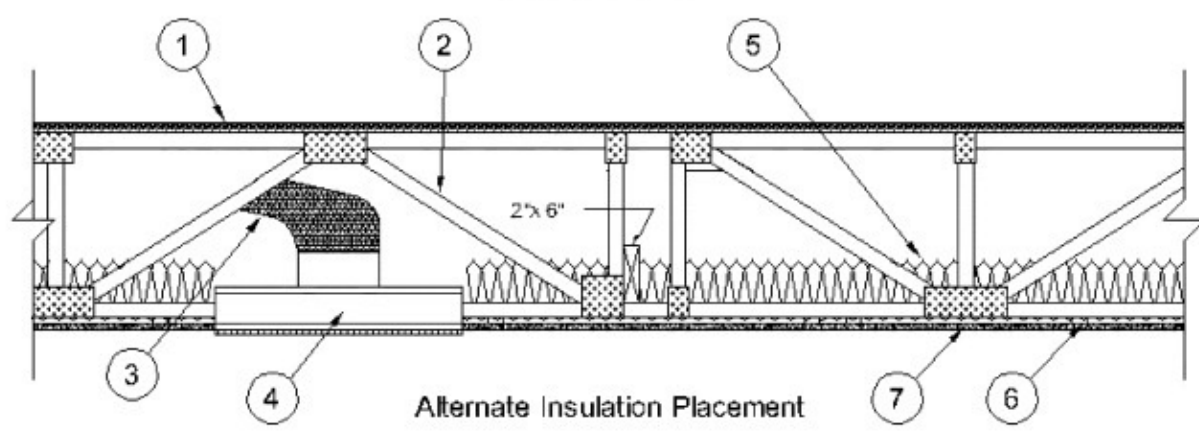

1. **Flooring System** — The flooring system shall consist of one of the following:

System No. 1

Subflooring — Min 15/32 in. thick wood structural panels, min grade "C-D" or "Sheathing". Face grain of plywood or strength axis of panels to be perpendicular to the joists with joints staggered.

Subflooring (Alternate) - Structural Cement-Fiber Units* — Nominal 19 mm (3/4 in.) thick tongue and groove structural cement-fiber units. Long dimension of panels to be perpendicular to trusses with end joints staggered. Panels fastened to the trusses with #10 self-drilling, self-tapping cement board screws 1-3/4 in. long. Screws shall be spaced 6 in. OC along the perimeter of each sheet and 12 in. OC in the field of each sheet. Screws shall be spaced 1/2 in. from end joints and 1 in. from side joints.

ECTEK INTERNATIONAL INC — Armoroc Panel

Vapor Barrier — (Optional) - Commercial asphalt saturated felt, 0.030 in. thick.

Vapor Barrier — (Optional) - Nom 0.010 in. thick commercial rosin-sized building paper.

Finish Flooring* — Min 3/4 in. thickness of any Floor Topping Mixture bearing the UL Classification Marking as to Fire Resistance. See Floor- and Roof-Topping Mixtures (CCOX) category for names of Classified Companies.

Floor Mat Materials* — (Optional) - Nom. 1/4 in. thick loose laid over the subfloor. Floor topping thickness shall be a minimum of 3/4 in.

KEENE BUILDING PRODUCTS CO INC — Type Quiet Qurl 55/025 and Quiet Qurl 55/025 N

Alternate Floor Mat Materials* — (Optional) - Floor mat material Nom. 3/8 in. thick loose laid over the subfloor. Floor topping thickness shall be a minimum of 1 in.

KEENE BUILDING PRODUCTS CO INC — Type Quiet Qurl 60/040 and Quiet Qurl 60/040 N

Alternate Floor Mat Materials* — (Optional) - Floor mat material Nom. 3/4 in. thick loose laid over the subfloor. Floor topping thickness shall be a minimum of 1-1/2 in.

KEENE BUILDING PRODUCTS CO INC — Type Quiet Qurl 65/075, Quiet Qurl 65/075 N

Alternate Floor Mat Materials* — (Optional) - Floor mat material Nom. 1/8 in. thick loose laid over the subfloor. Floor topping thickness shall be a minimum of 3/4 in.

KEENE BUILDING PRODUCTS CO INC — Type Quiet Qurl 52/013 and Quiet Qurl 52/013 N

Alternate Floor Mat Materials* — (Optional) - Floor mat material Nom. 1/4 in. entangled net core with a compressible fabric attached to the bottom loose laid over the subfloor. Floor topping thickness shall be a minimum of 1 in.

KEENE BUILDING PRODUCTS CO INC — Quiet Qurl 55/025 MT and Quiet Qurl 55/025 N MT

System No. 2

Subflooring — Min 15/32 in. thick wood structural panels, min grade "C-D" or "Sheathing". Face grain of plywood or strength axis of panels to be perpendicular to the joists with joints staggered.

Vapor Barrier — (Optional) — Nom 0.030 in. thick commercial asphalt saturated felt.

Vapor Barrier — (Optional) — Nom 0.010 in. thick commercial rosin-sized building paper.

Finish Flooring — Floor Topping Mixture* — Min 3/4 in. thickness of floor topping mixture having a minimum compressive strength of 1800 psi. Refer to manufacturer's instructions accompanying the material for specific mix design.

UNITED STATES GYPSUM CO — Types LRK, HSLRK, CSD

Floor Mat Materials* — (Optional) — Floor mat material loose laid over the subfloor. Refer to manufacturer's instructions regarding the minimum thickness of floor topping over each floor mat material.

UNITED STATES GYPSUM CO — Types SAM, LEVELROCK® Brand Sound Reduction Board, LEVELROCK® Brand Floor Underlayment SRM-25

2. **Trusses** — Parallel chord trusses, spaced a max of 24 in. OC, fabricated from nom 2 by 4 lumber, with lumber oriented vertically or horizontally. Min truss depth is 12 in. Truss members secured together with min 0.0356 in. thick galvanized steel plates. Plates have 5/16 in. long teeth projecting perpendicular to the plane of the plate. The teeth are in pairs facing each other (made by the same punch), forming a split tooth type plate. Each tool has a chisel point on its outside edge. These points are diagonally opposite each other for each pair. The top half of each tooth has a twist for stiffness. The pairs

are repeated on approx. 7/8 in. centers with four rows of teeth per inch of plate width.

3. **Air Duct*** — Any UL Class 0 or Class 1 flexible air duct installed in accordance with the instructions provided by the damper manufacturer.

4. **Damper*** — For use with min 18 in. deep trusses. Max nom 20 in. long by 18 in. wide by 2-1/8 in. high, fabricated from galvanized steel. Plenum box max size nom 21 in. long by 18 in. wide by 16 in. high fabricated from either galvanized steel or Classified Air Duct Materials bearing the UL Classification Marking for Class 0 or Class 1 rigid air duct material. Installed in accordance with the instructions provided by the manufacturer. Max damper openings not to exceed 180 sq in. per 100 sq ft of ceiling area.

NAILOR INDUSTRIES INC — Types 0755, 0755A, 0756, 0756D, 0757, 0757D, 0757FP, 0757DFP, 0758, 0759, 0760, 0761, 0762, CRD5, CRD5D, CRD6, CRD6D, CRD6FP, CRD6DFP

ROYAL METAL PRODUCTS INC — Models 241FRD, 243FRD, 505RD, 507RD, 509, 556RD, 556RDD, 557RD, 557RDD, 557RDFP, 557RDDFP, 0756, 0756D, 0757, 0757D, 0757FP, 0757DFP.

4A. **Damper*** — For use with min 18 in. deep trusses. Max nom 9 by 9 in. damper with Airzone fan installed in accordance with the instructions provided by the manufacturer. Max height of damper with fan shall be 11 in. Max damper openings not to exceed 180 sq in. per 100 sq ft of ceiling area.

PANAMEX GROUP INC — Type 0750HM

5. **Batts and Blankets*** — (Optional) - Glass fiber or mineral wool insulation bearing the UL Classification Marking as to Surface Burning Characteristics and/or Fire Resistance. When the resilient channels (Item 6) are spaced 16 in. OC, the insulation shall be a max of 3-1/2 in. thick, and shall be secured against the subflooring with staples at 12 in. OC or held suspended in the concealed space with 0.090 in. diam galv steel wires attached to the wood trusses at 12 in. OC. When the resilient channels are spaced a max of 12 in. OC or when the Steel Framing Members (Item 6A) are used, there is no limit in the overall thickness of insulation, and the insulation can be secured against the subflooring, held suspended in the concealed space or draped over the resilient channels (or Steel Framing Members) and gypsum panel membrane. The finished rating has only been determined when the insulation is secured to the subflooring.

5A. **Loose Fill Material*** — (Optional) - As an alternate to Item 5, when the resilient channels (Item 6) are spaced a maximum of 12 in. OC, or when the Steel Framing Members (Item 6A) are used - Any loose fill material bearing the UL Classification Marking for Surface Burning Characteristics. There is no limit in the overall thickness of insulation. The finished rating when loose fill material is used has not been determined.

6. **Furring Channels** — Resilient channels formed of 25 MSG thick galv steel, spaced 16 in. OC perpendicular to trusses. When insulation (Items 5 or 5A) is applied over the resilient channel/gypsum panel ceiling membrane, the resilient channel spacing shall be reduced to 12 in. OC. Channels secured to each truss with 1-1/4 in. long Type S bugle head steel screws. Channels overlapped 4 in. at splices. Two channels, spaced 6 in. OC, oriented opposite each gypsum panel end joint as shown in the above illustration. Additional channels shall extend min 6 in. beyond each side edge of panel.

6A. **Steel Framing Members* - (Not Shown)** — As an alternate to Item 6.

a. **Main Runners** — Nom 10 or 12 ft long, 15/16 in. or 1-1/2 in. wide face, spaced 4 ft OC perpendicular to trusses. Main runners hung a min of 2 in. from bottom chord of trusses with 12 SWG galv steel wire. Wires spaced 48 in. OC.

b. **Cross tees or channels** — Cross tees, nom 4 ft long, 15/16 in. or 1-1/2 in. wide face, or cross channels, nom 4 ft long, 1-1/2 in. wide face, installed perpendicular to the main runners, spaced 16 in. OC. Additional cross tees or channels used at 8 in. from each side of butted panel end joints. The cross tees or channels may be riveted or screw-attached to the wall angle or channel to facilitate the ceiling installation.

c. **Wall angles or channels** — Min 0.016 in. thick painted or galvanized steel angle with 1 in. legs or channel with a 1 by 1 1/2 by 1 in. profile, attached to walls at perimeter of ceiling with fasteners 16 in. OC. Used to support steel framing member ends and for screw-attachment of the gypsum panels.

CGC INC — Type DGL, RX

USG INTERIORS LLC — Type DGL, RX

6B. **Steel Framing Members*** — (Not Shown) - As an alternate to Items 6 and 6A.

a. **Furring Channels** — Formed of No. 25 MSG galv steel, 2-9/16 in. or 2-23/32 in. wide by 7/8 in. deep, spaced 12 in. OC perpendicular to wood structural members. Channels secured to trusses as described in Item b. Ends of adjoining channels overlapped 6 in. and tied together with double strand of No. 18 AWG galv steel wire near each end of overlap.

b. **Steel Framing Members*** — Used to attach furring channels (Item a) to trusses (Item 2). Clips spaced 12 in. OC, RSIC-1 and RSIC-1 (2.75) clips secured to consecutive trusses with No. 8 x 2-1/2 in. course drywall screw through the center grommet. RSIC-V and RSIC-V (2.75) clips secured to consecutive joists with No. 8 x 1-1/2 in. coarse drywall screw through the center hole. Furring channels are friction fitted into clips. RSIC-1 and RSIC-V clips for use with 2-9/16 in. wide furring channels. RSIC-1 (2.75) and RSIC-V (2.75) clips for use with 2-23/32 in. wide furring

channels. Adjoining channels are overlapped as described in Item a. As an alternate, ends of adjoining channels may be overlapped 6 in. and secured together with two self-tapping No. 6 framing screws, min 7/16 in. long at the midpoint of the overlap, with one screw on each flange of the channel. Additional clips required to hold furring channel that supports the gypsum board butt joints, as described in Item 7.

PAC INTERNATIONAL INC — Types RSIC-1, RSIC-V, RSIC-1 (2.75), RSIC-V (2.75).

6C. Steel Framing Members* — (Optional, Not Shown) - Used as an alternate method to attach min. 1/2 in. deep resilient channels (Item 6) to wood trusses (Item 2). Resilient channels are friction fitted into clips, and then clips are secured to the bottom chord of each wood truss with a min. 1-3/4 in. long Type S bugle head steel screw through the center hole of the clip and the resilient channel flange. Adjoining resilient channels are overlapped 4 in. under trusses. The clip flange is opened slightly to accommodate the two overlapped channels. Additional clips required to hold resilient channel that supports the gypsum board butt joints, as described in Item 7.

KEENE BUILDING PRODUCTS CO INC — Type RC Assurance.

6D. Alternate Steel Framing Members — (Not Shown)* — As an alternate to Items 6, 6A, 6B, and 6C, furring channels and Steel Framing Members as described below.

a. **Furring Channels** — Formed of No. 25 MSG galv steel, 2-5/8 in. wide by 7/8 in deep, spaced 12 in OC, perpendicular to trusses. Channels secured to joists as described in Item b.

b. **Steel Framing Members*** — Used to attach furring channels (Item a) to the wood trusses (Item 2). Clips spaced at 12" OC and secured to the bottom of the trusses with one No. 10 x 2-1/2 Coarse Drywall Screw through the center hole. Furring channels are then friction fitted into clips. Ends of channels are overlapped 6" and screwed with four No. 8 x 1/2 Self Drilling screws (2 per side 1 in. and 4 in. from overlap edge). Additional clips are required to hold the Gypsum Butt joints and side joints as described in Item 7.

STUDCO BUILDING SYSTEMS — RESILMOUNT Sound Isolation Clips - Type A237 or A237R

7. Gypsum Board* — Nom 5/8 in. thick, 48 in. wide gypsum panels. When resilient channels (Item 6) are used, gypsum panels installed with long dimension perpendicular to resilient channels. Gypsum panels secured with 1 in. long Type S bugle head steel screws spaced 12 in. OC and located a min of 1/2 in. from side joints and 3 in. from end joints. When insulation (Items 5 or 5A) is applied over the resilient channel/gypsum panel ceiling membrane the screw spacing shall be reduced to 8 in. OC. End joints secured to both resilient channels as shown in end joint detail. When Steel Framing Members (Item 6A) are used, gypsum panels installed with long dimension perpendicular to cross tees with side joints centered along main runners and end joints centered along cross tees. Panels fastened to cross tees with 1 in. long Type S bugle-head screws spaced 8 in. OC in the field and along end joints. Panels fastened to main runners with 1 in. long Type S bugle-head screws spaced midway between cross tees. Screws along sides and ends of panels spaced 3/8 to 1/2 in. from board edge. End joints of panels shall be staggered with spacing between joints on adjacent panels not less than 2 ft OC. When Steel Framing Members (Item 6B) are used, gypsum panels installed with long dimensions perpendicular to furring channels. Panels attached to the furring channels using 1 in. long Type S bugle-head steel screws spaced 8 in. OC along butted end joints and in the field of the panel. Butted end joints shall be staggered min. 2 ft within the assembly, and occur midway between the continuous furring channels. Each end of each gypsum panel shall be supported by a single length of furring channel equal to the width of the gypsum panel plus 6 in. on each end. The two support furring channels shall be spaced approximately 3-1/2 in. OC, and be attached to underside of the truss with one clip at each end of the channel. When **Steel Framing Members** (Item 6D) are used, one layer of nom 5/8 in. thick, 4 ft wide gypsum board is installed with long dimensions perpendicular to furring channels. Gypsum board secured to furring channels with nom 1 in. long Type S bugle-head steel screws spaced 8 in. OC in the field of the board. Gypsum board butted end joints shall be staggered minimum 72 in. At the gypsum board butt joints, each end of each gypsum board shall be supported by a single length of furring channel equal to the width of the gypsum board plus 3 in. on each end, spaced approximately 2 in. in from joint. Screw spacing along the gypsum board butt joint shall be 8 in. OC. Butt joint furring channels shall be attached with a RESILMOUNT Sound Isolation Clip secured to underside of every joist that is located over the butt joint. Over all Gypsum Board side joints, approximately 20 in. lengths of furring channel shall be installed parallel to the channel (Item 2) between main furring channels. Side joint furring channels shall be attached to underside of the truss with RESILMOUNT Sound Isolation Clips - located approximately 2 in. from each end of the approximate 20 in. length of channel. Both Gypsum Boards at side joints fastened into channel with screws spaced 8 in. OC, approximately 1/2 in. from joint edge.

CGC INC — Types C, IP-X2, IPC-AR

UNITED STATES GYPSUM CO — Types C, IP-X2, IPC-AR

USG MEXICO S A DE C V — Types C, IP-X2, IPC-AR

8. Finishing System — (Not Shown) — Vinyl, dry or premixed joint compound, applied in two coats to joints and screw-heads. Nom 2 in. wide paper tape embedded in first layer of compound over all joints. As an alternate, nom 3/32 in. thick veneer plaster may be applied to the entire surface of gypsum board.

* Indicates such products shall bear the UL or cUL Certification Mark for jurisdictions employing the UL or cUL Certification (such as Canada), respectively.

Last Updated on 2015-02-26

[Questions?](#)

[Print this page](#)

[Terms of Use](#)

[Page Top](#)

© 2015 UL LLC

When the UL Leaf Mark is on the product, or when the word "Environment" is included in the UL Mark, please search the [UL Environment database](#) for additional information regarding this product's certification.

The appearance of a company's name or product in this database does not in itself assure that products so identified have been manufactured under UL's Follow-Up Service. Only those products bearing the UL Mark should be considered to be Certified and covered under UL's Follow-Up Service. Always look for the Mark on the product.

UL permits the reproduction of the material contained in the Online Certification Directory subject to the following conditions: 1. The Guide Information, Assemblies, Constructions, Designs, Systems, and/or Certifications (files) must be presented in their entirety and in a non-misleading manner, without any manipulation of the data (or drawings). 2. The statement "Reprinted from the Online Certifications Directory with permission from UL" must appear adjacent to the extracted material. In addition, the reprinted material must include a copyright notice in the following format: "© 2015 UL LLC".